

N/F
ALGONQUIN COUNCIL
BOY SCOUTS OF AMERICA
BOOK 20135 PAGE 53
MAP 3D PARCEL 21

N/F
JAMES M. GARRITY &
KIMBERLY BROWN
BOOK 59930 PAGE 66
MAP 3D PARCEL 32

N/F
JAKE GORDON FOOTE
BOOK 10223 PAGE 400
MAP 3D PARCEL 7

N/F
ADRIAN J. & SHARON W. FLATGARD
32 CENTURY MILL ROAD
BOOK 7141 PAGED 150
MAP 3D PARCEL 29

N/F
KEITH M. LUNDBERG & MICHELE A. WADE
28 CENTURY MILL ROAD
BOOK 36004 PAGE 229
MAP 3D PARCEL 28



TYPICAL CULTEC RECHARGER R330XLHD ROOF INFILTRATION BED SECTION
(LOT 2 & LOT 4)
NOT TO SCALE

TYP. ROOF INFILTRATION BED
(LOT 2 & LOT 4)
NOT TO SCALE

NOTES

- COMMON DRIVEWAY SHOWN IS SUBJECT TO A MAINTENANCE AGREEMENT TO BE RECORDED AT THE W.D.R.D.
- NO COMMON DRIVEWAYS OR APPROVED OR ACCEPTED PUBLIC WAYS EXIST ON THE SAME SIDE OF CENTURY MILL ROAD WITHIN 200 FEET OF THE PROPOSED COMMON DRIVEWAY CENTERLINE INTERSECTION WITH CENTURY MILL ROAD.
- PORTIONS OF THE SITE ARE LOCATED WITHIN FEMA DESIGNATED FLOOD ZONE AE. FLOOD ZONES SHOWN ARE THE RESULT OF AN ON THE GROUND SURVEY REFERENCED TO FEMA SPECIFIED BASE FLOOD ELEVATION (ELEVATION = 310' NAVD88).
- ALL ELEVATIONS REFER TO NAVD88 DATUM.

SEE SPECIAL PERMIT ISSUED BY BOLTON PLANNING BOARD DATED: _____

SEE COMMON DRIVEWAY MAINTENANCE AGREEMENT RECORDED AT W.D.R.D. IN BOOK _____ PAGE _____

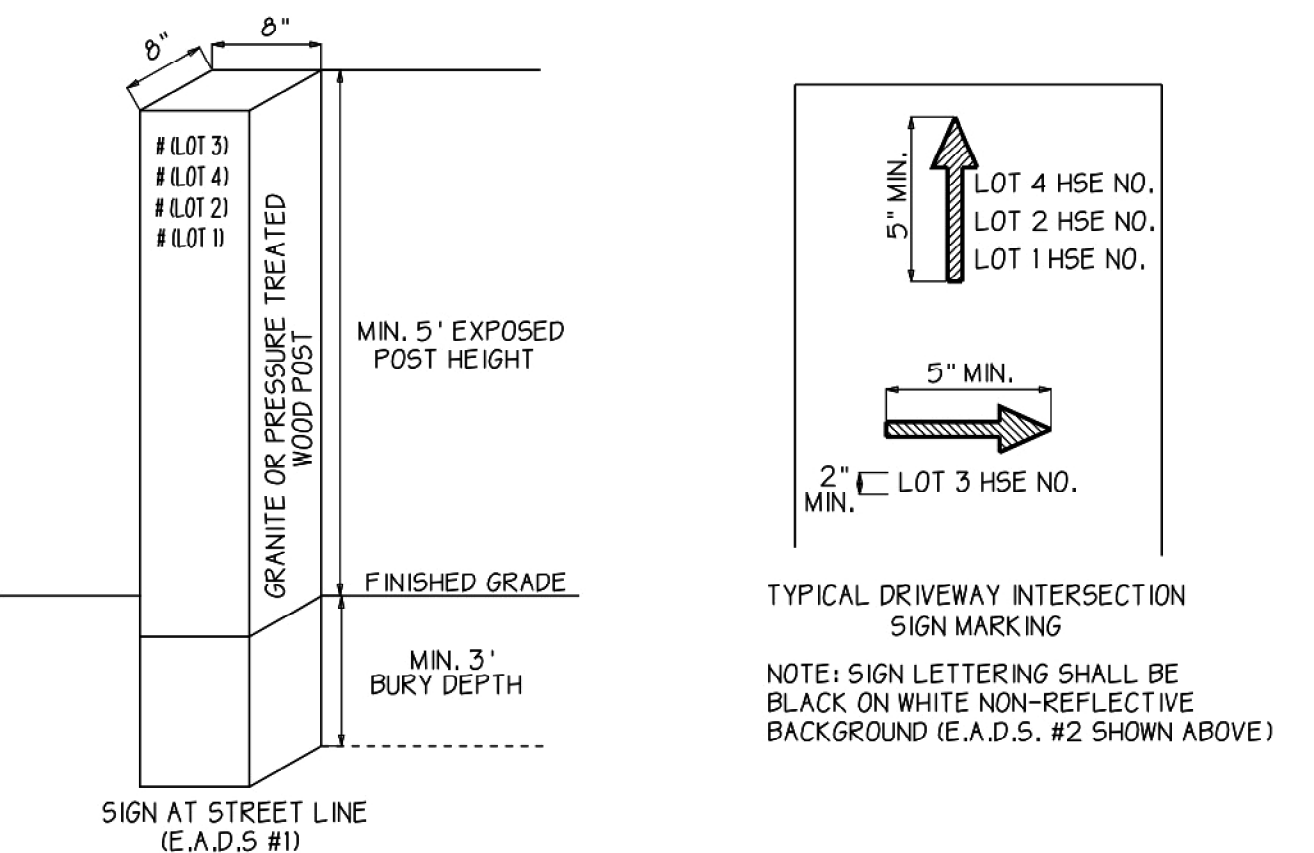

TYPICAL EMERGENCY ACCESS DIRECTION SIGN (E.A.D.S.)
NOT TO SCALE

SIGNS TO DIRECT EMERGENCY RESPONSE VEHICLES MUST BE INSTALLED AT STREET LINE AND AT EACH DRIVEWAY INTERSECTION ALONG THE COMMON DRIVEWAY AT LOCATIONS SHOWN.
THE SIGN AT THE STREET LINE WILL DESIGNATE ALL ADDRESSES SERVED BY THE COMMON DRIVEWAY.
SIGNS AT EACH DRIVEWAY INTERSECTION SHALL INCLUDE ARROWS INDICATING GENERAL DIRECTION TO EACH DWELLING ALONG THE COMMON DRIVEWAY, AS SHOWN TYPICALLY ABOVE.
STREET NUMBERS FOR EACH LOT SERVED BY THE COMMON DRIVEWAY SHALL BE ASSIGNED BY THE BOLTON BUILDING INSPECTOR.

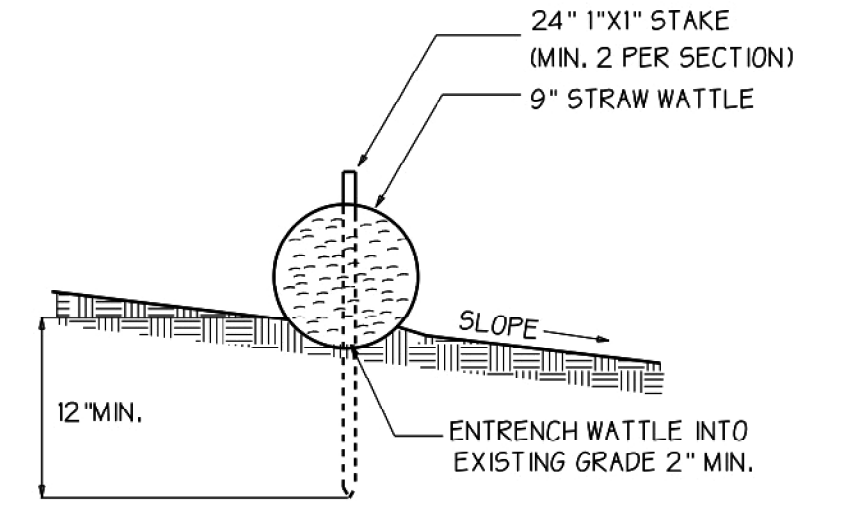

STAKED STRAW WATTLE EROSION CONTROL BARRIER
NOT TO SCALE

COMMON DRIVEWAY PLAN & PROFILE

LOTS 1-4 CENTURY MILL ROAD

BOLTON, MASSACHUSETTS
ASSESSORS MAP 3D PARCEL 75

PREPARED FOR:
21 CENTURY MILL LLC
291 MAIN STREET SUITE 8
NORTHBOROUGH, MA 01532
REV. 11/24/20 - BL/SF RESTORATION AREA; 1/9/21 FLOOD STORAGE; ECB LOT 2; 3/19/21 - GRADING & MITIGATION
DATE: AUGUST 11, 2020 SCALE: 1 INCH = 40 FEET

ENGINEERING SURVEYING PLANNING

FORESITE ENGINEERING
16 Gleasondale Road Suite 1-1
Stow, Massachusetts 01775
Phone: (978)461-2350

www.foresite.com
COPYRIGHT 2021 FORESITE ENGINEERING ASSOCIATES, INC. 1979510.2D

